



# Efficient Injection Molding EVOS Series Machines

*Engineering Excellence*



## Areas of Application for the EVOS Series



Closures



Packaging



Medical components



Technical components

### On top

Bottle closures pose a challenge for many injection molding machines. However, the high-performance and high-precision EVOS is ideally suited to the manufacture of closures, while its large clamping surfaces provide sufficient space for molds with a high number of cavities.

### Well packed: in-mold labeling (IML)

There is growing demand for the simultaneous labeling of packaging parts during injection molding. As well as the functional benefits that this sophisticated process brings, there is also considerable potential for cost savings.

### Medical consumables

Thanks to its closed-loop lubrication system and completely sealed drive unit, the EVOS is also brilliantly suited for use in clean rooms.

### High-precision technical components

The EVOS is setting a strong trend for new and innovative technologies such as embossing processes and gas and water injection technology.

## EVOS Series Machines The “fine Art” of Injection Molding

The EVOS stands for efficient high-performance injection molding and, thanks to hybrid drive technology, reduced energy consumption. The machine's modular system means that the clamping unit, plasticizing unit and drive are freely selectable, making the machine customizable for virtually any application. By dividing the clamping and injection units into two separate machine modules, it is also possible to run manufacturing and assembly processes in parallel.

### The benefits of the EVOS series at a glance

- Powerful
- Energy-efficient
- User-oriented
- Precise and fast
- Flexible

# Efficient Injection Molding

## A Fascinating Tour of the EVOS

**Flexible media module**  
Machine can be adapted to your requirements in a variety of ways

**Modern control technology**  
Easy handling thanks to Windows-based interface

**High-performance injection unit**  
Hybrid-powered injection unit with extremely high injection rate and maximum control precision



**Precise and dynamic clamping unit**  
thanks to 5-point double toggle lever and hydromechanical drive technology

**Clean mold mounting area**  
Completely oil-free clamping unit thanks to closed-loop lubrication system and moving mold plate support on stable linear guides

**Innovative drive unit**  
"Eco Powerunit" with optimized energy efficiency

## Clamping and Injection Unit Solutions of the EVOS Series

We focus on your needs by providing you with an EVOS that is tailored to your requirements to optimize production process control. The clamping unit, injection unit, drive and screw diameter can be optimally configured according to machine application.

**EVOS: the machine series with a modular system for universal applications**

Injection unit	1000			2000			2900		4200		6000	
Screw Ø	45	50	55	55	62	70	70	80	80	90	90	100
<b>Clamping Unit</b>												
3000 kN												
3500 kN												
4500 kN												
5500 kN												

### Your benefits:

- Consistently modular construction
- Configurable to your requirements
- Flexible upgrades for future applications

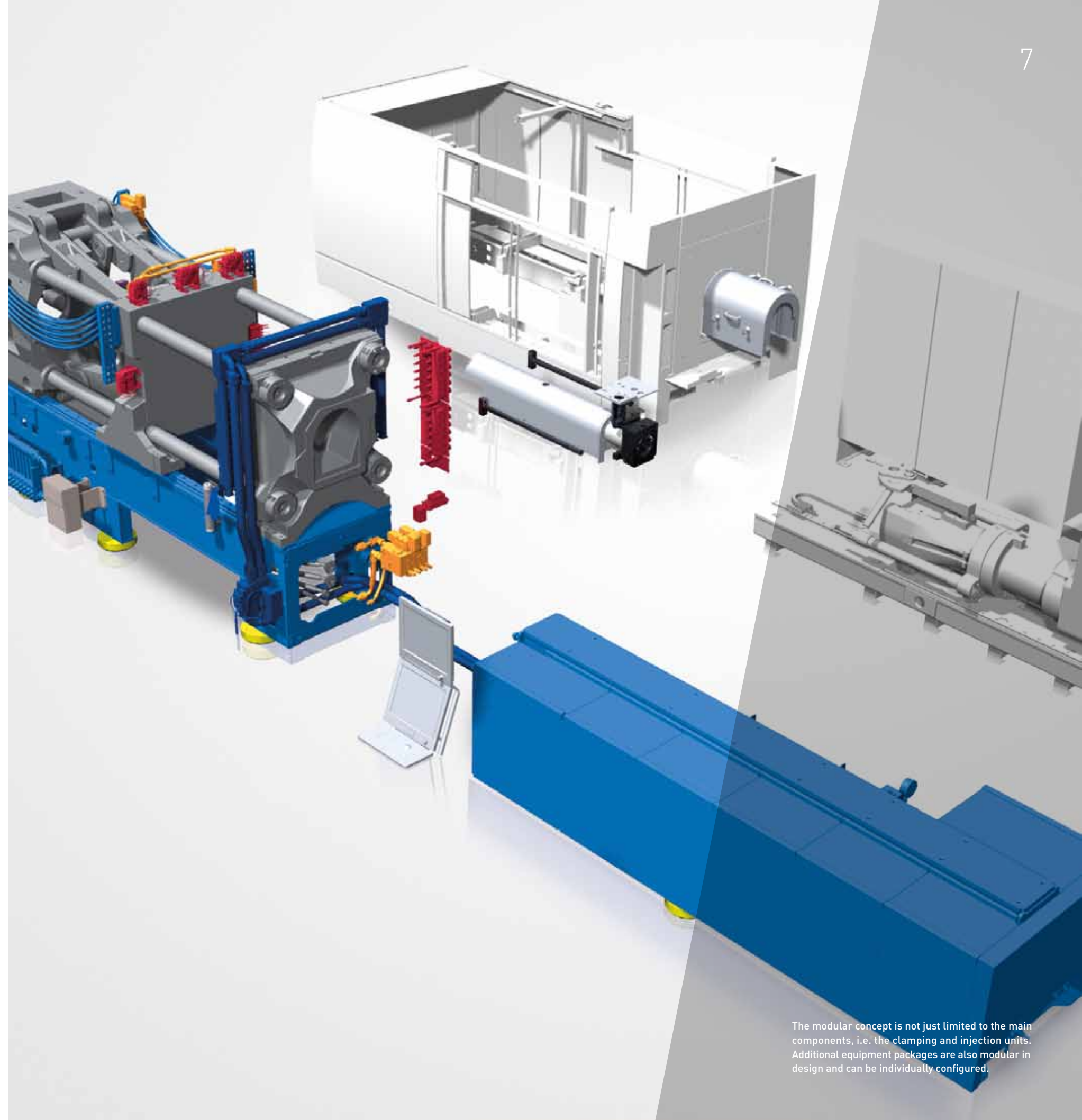

The modular concept is not just limited to the main components, i.e. the clamping and injection units. Additional equipment packages are also modular in design and can be individually configured.

## High Speed Minimal Dimensions

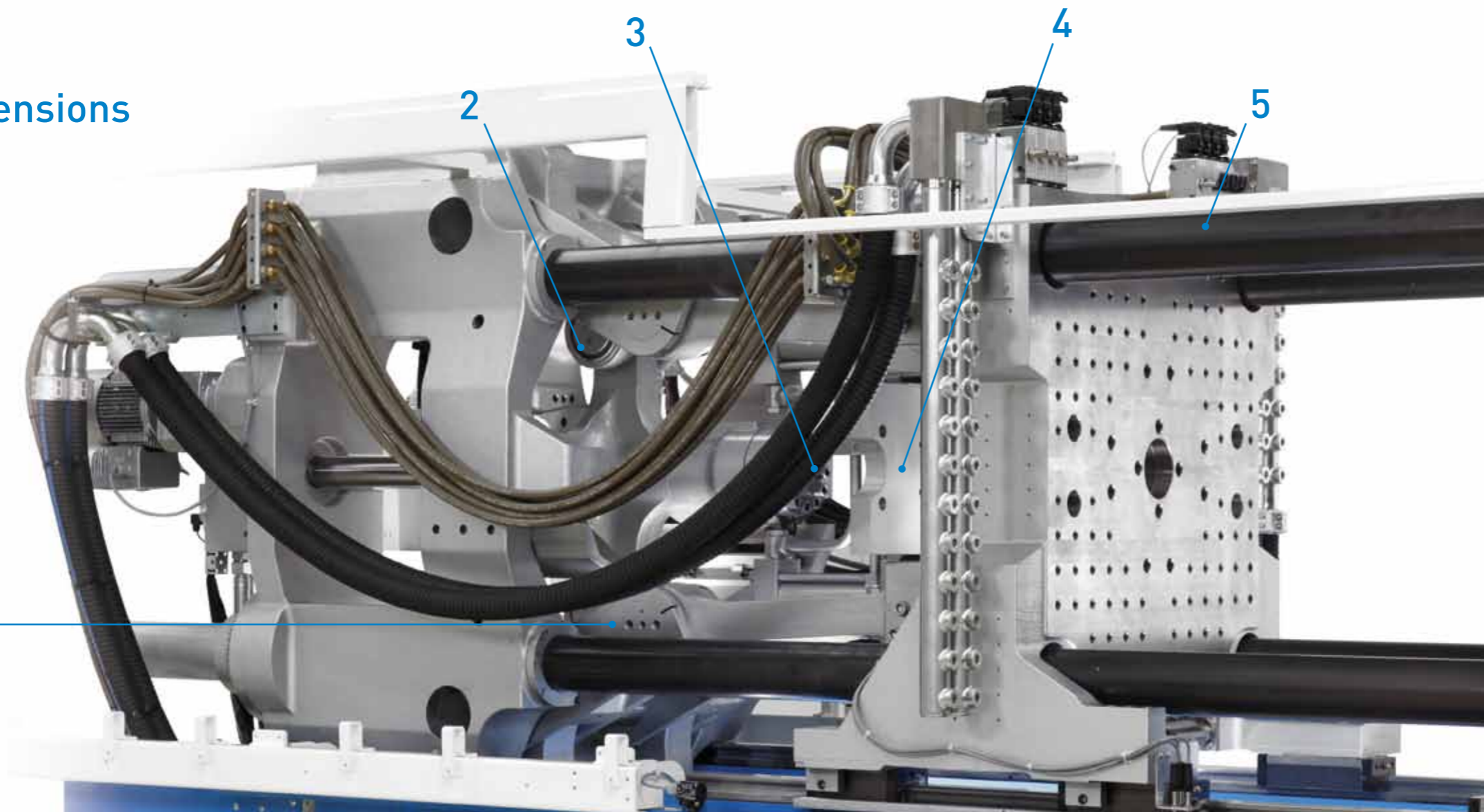

Transfer of force through centrally inclined 5-point toggle lever



Reduced footprint thanks to inward-facing closing cylinder



EVOS can be optionally equipped with a freely movable support for stack molds.

1

The EVOS clamping unit is based on the 5-point toggle lever system that is an established component at Netstal. Placing the inward-facing closing cylinder inside the toggle lever area has created a space-saving construction. The robust design allows for high speeds despite minimal dimensions. Optimal movement sequences and highly precise starting positions are achieved through the digital control of clamping unit movements.

### 1. Closed-loop circulatory lubrication system

The closed-loop lubrication system services the sealed bearings in the toggle lever system. Lubricating oil is cleaned continuously.

### 2. Centrally aligned toggle lever

The 5-point double toggle lever ensures optimal transfer of force to the center of the mold mounting area and even distribution of clamping force. The extremely stable and robust construction effectively prevents deformation of the clamping plates.

### 3. Inward-facing closing cylinder

The closing cylinder is situated on the inside of the toggle lever system. Thanks to the space saved at the front of the machine, the machine footprint is greatly reduced. This means greater efficiency within a smaller square meterage.

### 4. Flexible ejector

Straightforward demolding of parts: highly dynamic proportional valves, which are available in three different sizes depending on the required ejection force, regulate two cylinders. Using the optional "Booster"

feature, even injection parts that are firmly shrunk onto the cavity are easily demolded.

### 5. Extended tie-bar distance

The large tie-bar distance and generous opening stroke enable straightforward mounting of molds with large cavity numbers. Tie-bar retraction has been radically simplified for easier mounting and removal of oversized molds.

## Powerful Performance Low Energy Consumption

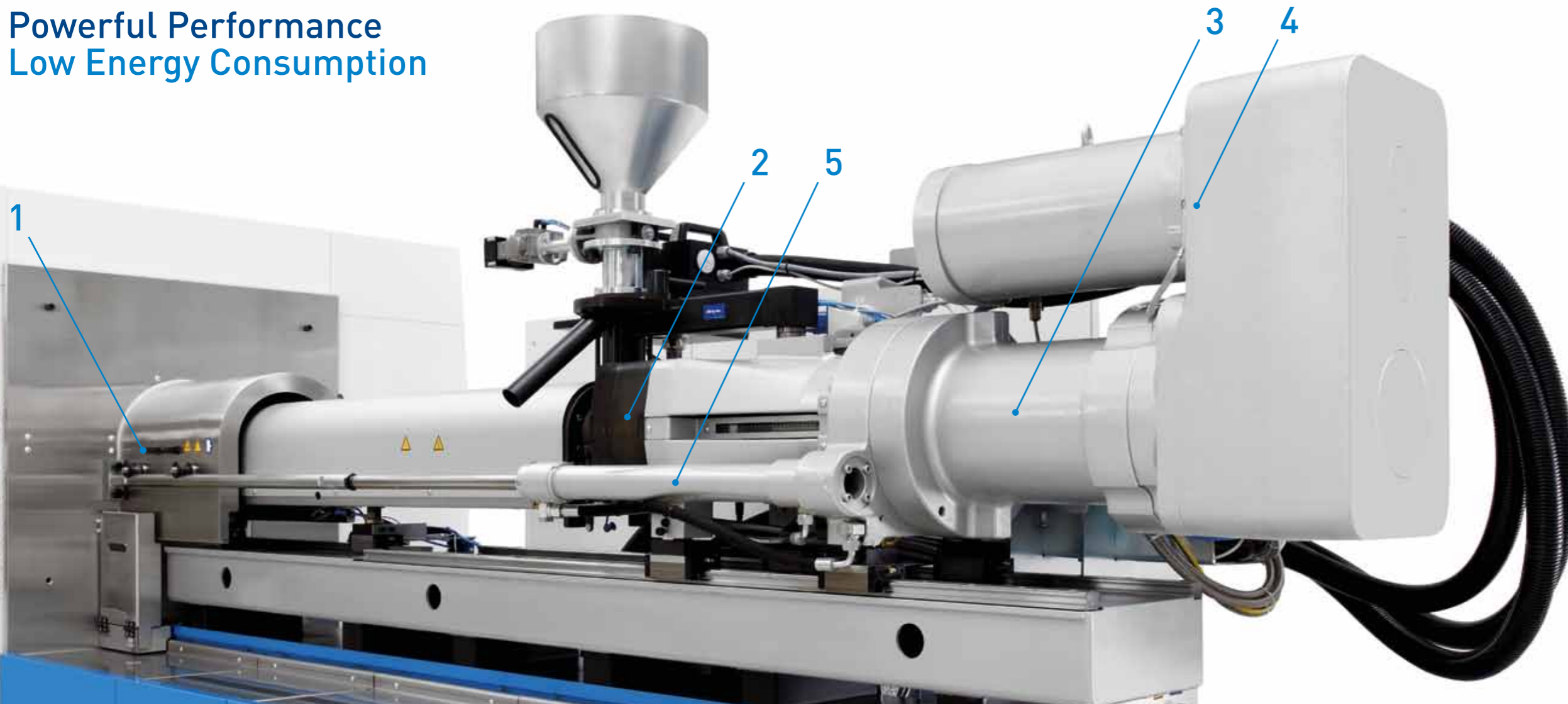

Optimized process control thanks to actively controlled nozzle needle valve



Auxiliary mold control: extremely dynamic thanks to state-of-the-art valve technology

The EVOS provides the ultimate in flexibility:

The injection process can be optimally tailored to the customer's requirements with a choice of injection and plasticizing unit sizes. The injection unit's hybrid drive guarantees powerful injection performance, while the servo-electric drive of the metering axis ensures low energy consumption.

### 1. Actively controlled nozzle needle valve

The active triggering of the nozzle needle valve means that the nozzle needle can move unimpeded during injection.

### 2. Simplified plasticizing unit exchange

The plasticizing unit is equipped with a special clamping system. Thanks to easy accessibility from above, the plasticizing unit can be exchanged without any great difficulty. Plug-in interfaces for air, water and electrics allow for quick and simple changing of the plasticizing unit.

### 3. Powerful injection axis

The injection axis is driven hydraulically by means of two highly dynamic valves, which ensures extremely high acceleration values, a high level of injection performance and precise control characteristics during the injection and hold pressure process. The new approach also makes a high degree of accuracy and reproducibility possible in terms of the metering stroke. Up to four different screw diameters are available for each injection unit size to ensure an optimal selection of screws for any application.

### Two-valve technology

Highly dynamic servo valves with a flow rate of up to 2 x 550 l/min and a response time of max. 11 ms: this technology makes it possible to reach top injection speeds of up to 2.0 m/s. Boasting acceleration of up to 20 G, the EVOS is also setting standards when it comes to dynamics. Despite this, the machine's high positioning accuracy is still maintained.

### 4. Servo-electric screw drive

The metering axis is available in two different performance classes, Speed and Master, and is powered by a servo motor and spur gearing. The torque achieved in "Master" mode is elevated compared to standard torque levels, which are already high.

### 5. Integrated stroke measuring system

The compression axis meets the highest requirements in terms of dynamics and positioning accuracy. The stroke measuring system is integrated into the hunt cylinder.

Innovative solutions, optimum energy efficiency  
The high efficiency of the clamping unit can be attributed in large part to the low-friction movements of the moving mold plate.

## Low Energy, High Performance Efficient Drive Concept

Energy efficiency has been greatly improved thanks to the new drive concept debuted by the EVOS series: the advent of the Eco Powerunit means that unprecedented energy savings are made when using hydraulic and hybrid injection molding machines. The following attributes have a key role to play here:

- Kinetic energy recovery
- Adaptive drive control
- Interconnection of power converters
- Optional operating point at maximum efficiency

Based on the low consumption data in the graph, the EVOS is a machine that stands for maximum efficiency. When coupled with the Eco Powerunit, it delivers energy savings of up to 30 percent compared to conventional hydraulic machines. If an all-electric machine is used, efficiency is increased again by around a further 30 percent.

### Energy efficiency is more than just a buzzword

It is anticipated that energy costs will rise further in the future to become the second most important cost factor after material costs. Netstal is committed to developing innovative systems and solutions that ensure optimal energy efficiency at maximum productivity in line with our motto: "Low Energy, High Performance".

Energy consumption comparison

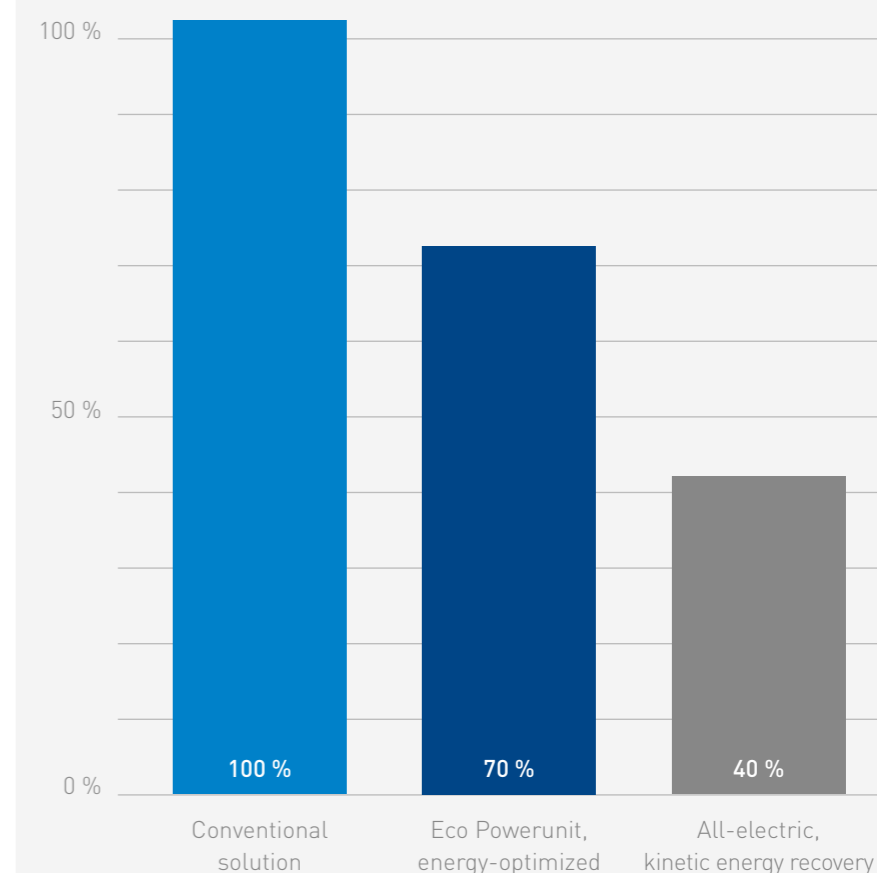

## Simply Clever Highest Media Flexibility

### Pneumatic valves

Pneumatic valves are installed close to the consumer to ensure faster response times.

### Hydraulic controls

The connections for hydraulic auxiliary mold controls can be installed on the operating or non-operating side of the machine as preferred.

### Cooling water distributor

Depending on the mold, cooling water distributors are available for any position on the mold plates. The distributors are protected against corrosion and an optimal flow rate is guaranteed thanks to the use of ball valves.

### Multiple socket outlets

Multiple socket outlets with integrated circuit breakers can be installed in various positions on the machine to connect peripheral devices.

---

### Your benefits:

- Optimal accessibility
  - Easy to use
  - Extremely easy to maintain
  - Maximum efficiency
- 

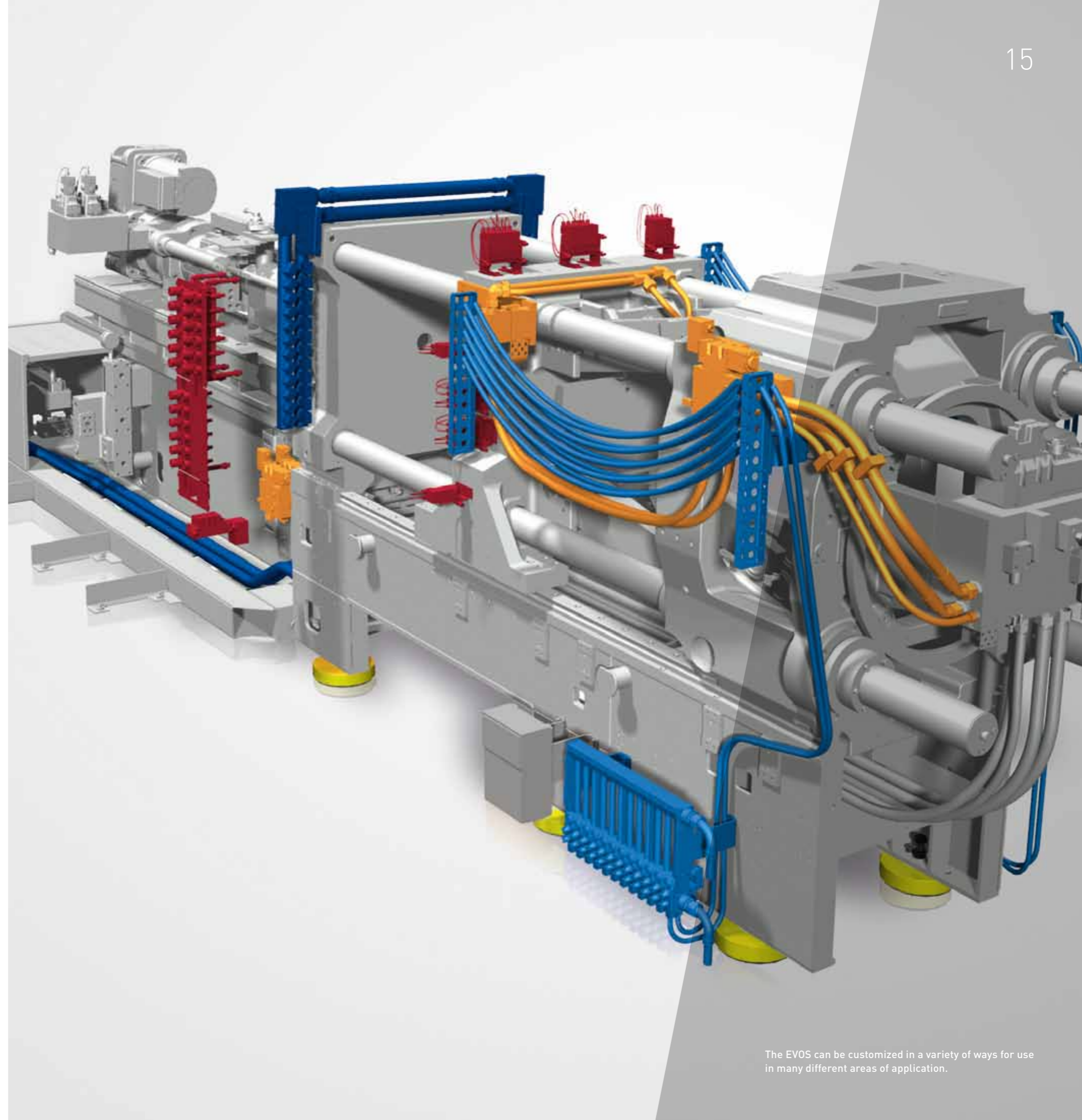



## aXos Control Innovative and user-friendly

The aXos control enables users to create the production processes they require in a way that is both customizable and cost-effective.



The aXos\* operating philosophy brings together the very different requirements of operators from the many areas of application in which injection molding machines are used. Consequently, the operating keyboard offers users a range of facilitating functions, such as shortcut buttons for quick access to desired topics, or the 17-inch TFT flat screen, which serves as a display medium for the entire programming setup.

### Sequence editor

The sequence editor can be used to create a graphical representation of any production process, into which simple commands can then be subsequently incorporated using the corona by moving the cursor. The corona is context-sensitive and offers optional commands and available insertion points for these commands.

### Component manager

The component manager covers all the non-primary axes of a machine (e.g. auxiliary mold controls, blowing controls, conveyor belts, reject gate, etc.), which can be created for individual upgrades and freely configured by the user.

### Operating keyboard

The operating keyboard is equipped with shortcut buttons to provide fast access to topics, as well as having navigation buttons, a trackball and a numeric keypad. The keyboard is ergonomically designed and can be folded down during maintenance.

### 17-inch flat screen

Serving as a display medium for the entire programming setup, the flat screen is slightly tilted to optimize screen readability. Users can navigate the TFT flat screen using cursor buttons or the centrally located trackball.

### Operating panel

#### (keyboard for manual operation)

The operating panel offers a whole range of functions to support user operation of the machine during day-to-day work. The combination of screen and membrane keyboard is a development that has been patented by Netstal.

### Your benefits:

- Flexible sequence programming
- All-purpose
- Intuitive operating concept
- Effective safety mechanisms
- Efficient thanks to graphical programming



- 1 Field for process value display
- 2 Field for system message list
- 3 Navigation to topics
- 4 Sequence editor / aXos task pane
- 5 Command parameter field
- 6 User ID
- 7 Global functions
- 8 Activation field
- 9 Status display

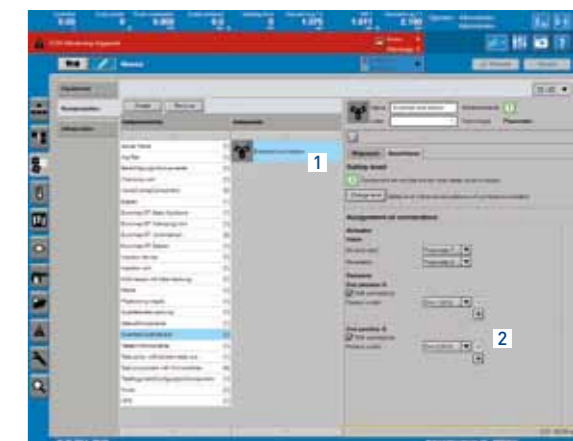

- 1 Created component "Switched core traction"
- 2 Assignment of (sensors/actuators)

\*aXos will also be available for EVOS in the future.

## Netstal Life Cycle Services – A Partnership to Last a Machine's Lifetime



Netstal's customer service provides you with optimum support throughout the entire life of your machine. Our solution-oriented services and products such as commissioning support, troubleshooting, spare parts supply and customer training optimize your production efficiency and secure your investment to create a life-long partnership that works to your advantage.

### Start-up phase

- Commissioning
- Training
- Maintenance consultation
- Parts finder

### Optimization phase

- Upgrades
- Energy optimization
- Production optimization
- Remote Support

### Utilization phase

- 24-hour spare parts hotline
- Inspection
- Calibration
- Hotline – technical customer service

### End phase

- Relocation of production
- Overhaul
- Rental and lease machines
- Trade of used machines

## Netstal A strong brand in a unique global group

### Premium high-performance and high-precision Injection Molding Machinery and system solutions

Netstal is an international provider of premium high-performance and high-precision Injection Molding Machinery and system solutions. Our customers are always impressed by the innovations and services that we provide, as well as by our efficient and performance-driven technological approaches for the beverage, packaging and medical technology sectors in particular. Our production systems are all characterized by the same attributes: speed, precision, reli-

ability, user friendliness and operational efficiency. We are constantly refining our technological standard of excellence and, thanks to our innovative technologies, we are able to offer high-performance production systems to our customers.

### There for you around the world

With eight subsidiaries and around 30 distributors, our global presence guarantees optimum customer proximity. This means that we are able to address your individual needs as quickly as possible and provide you with a comprehensive and customer-oriented service.

### Individualized service

While our customer service supports you with a range of solution-oriented services and products, it also excels as a provider of "classic" services thanks to its high reliability and quality standards. Be it commissioning, troubleshooting or customer training – make the most of our first-class services.

You can find additional information about Netstal at: [www.netstal.com](http://www.netstal.com)

## KraussMaffei Group Comprehensive expertise

### Unique selling proposition Technology<sup>3</sup>

The KraussMaffei Group is the only provider in the world to possess the essential machine technologies for plastics and rubber processing with its KraussMaffei, KraussMaffei Berstorff and Netstal brands: Injection Molding Machinery, Automation, Reaction Process Machinery and Extrusion Technology.

The group is represented internationally with more than 30 subsidiaries and over ten production plants as well as about 570 commercial and service partners. This is what makes us your highly skilled and integrated partner. Use our comprehensive and unique expertise in the industry.

You can find additional information at: [www.kraussmaffei.com](http://www.kraussmaffei.com)



The KraussMaffei Group has a global presence. Countries with subsidiaries are marked in light blue. In the white-colored regions, the Group is represented by over 570 sales and service partners.

Powerful.  
Flexible.  
Energy-Efficient.  
**EVOS Series Machines**

The EVOS possesses all the typical traits of a Netstal machine: speed, precision, reliability, user friendliness and, above all, cost-efficiency. It was developed for complex universal applications and increases your manufacturing process productivity. The idea here is that the more efficient the sequences in a production process, the more profitable the process as a whole.

The EVOS boasts a range of innovative technological features that make highperformance injection molding more efficient than ever before. The main modules, comprising the clamping unit, injection unit, drive, safety cover and control, are perfectly coordinated and geared toward efficient production.